

1200V N-Channel SiC Power MOSFET & SiC SBD

Description

The AKM4CM040N120M is a high blocking voltage N-Channel SiC power MOSFET. This device provide excellent performance for high voltage power supplies or pulse circuits.

These SiC MOS Module series are ideally suited for Solar and UPS Inverters, High Voltage DC/DC Converters, Motor Drivers, Switch Mode Power Supplies where switching losses are significant portion of the total losses.

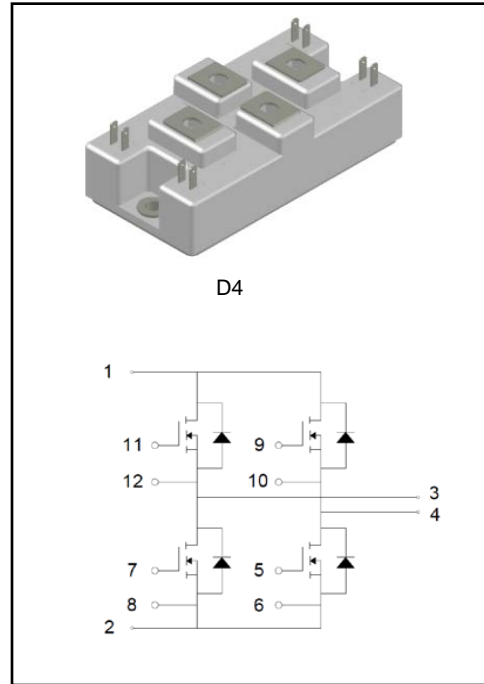

Features

- Typical on-Resistance: $R_{DS(on)}=40m\Omega$ @ $V_G=18V$
- High Blocking Voltage
- High Speed Switching with Low Capacitance
- Good Stability and Uniformity with High E_{AS}

Applications

- Solar and UPS Inverters
- High Voltage DC/DC Converters
- Motor Drivers
- Switch Mode Power Supplies
- Battery Chargers

Absolute Maximum Ratings @ $T_C=25^\circ C$ unless otherwise noted

Symbol	Parameter	Ratings	Unit
V_{DSS}	Drain to Source Voltage	1200	V
V_{GSS}	Gate to Source Voltage	-8/+22	V
V_{GSop}	Recommended operation Values of Gate-Source Voltage	-5/+18	V
I_D	Drain Current	$V_{GS}=15V, T_C=25^\circ C$	65
		$V_{GS}=15V, T_C=100^\circ C$	50
I_{DM}	Pulsed Drain Current (Note 1)	120	A
P_D	Maximum Power Dissipation $T_C=25^\circ C$	500	W
E_{AS}	Single Pulsed Avalanche Energy (Note 2)	1050	mJ
T_J	Operating Junction Temperature Range	-55~+175	$^\circ C$
T_{STG}	Storage Temperature Range	-55~+175	$^\circ C$

Static Electrical Characteristics @T_c=25 °C unless otherwise noted

Symbol	Parameter	Conditions	Min.	Typ.	Max.	Unit
BV _{DSS}	Drain to Source Breakdown Voltage	V _{GS} =0V, I _D =100uA	1200	-	-	V
V _{GS(th)}	Gate Threshold Voltage	V _{DS} =V _{GS} , I _D =9.5mA	2.0	3.0	4.0	V
R _{DS(on)}	Static Drain-Source On-Resistance	V _{GS} =18V, I _D =33.3A	-	40	52	mΩ
		V _{GS} =18V, I _D =33.3A T _C =175 °C	-	66	-	
R _{G(int)}	Internal Gate Resistance	T _C =25 °C	-	3.8	-	Ω
I _{DSS}	Zero Gate Voltage Drain Current	V _{DS} =V _{DSS} , V _{GS} =0V	-	3	100	uA
I _{GSS+}	Gate to Source Leakage Current	V _{GS} =22V, V _{DS} =0V	-	10	250	nA
I _{GSS-}	Gate to Source Leakage Current	V _{GS} =-8V, V _{DS} =0V	-	10	250	nA
g _{fs}	Transconductance	V _{DS} =20V, I _D =33.3A	-	22	-	S
		V _{DS} =20V, I _D =33.3A, T _C =175 °C	-	20.5	-	

Switching Characteristics @T_c=25 °C unless otherwise noted

Symbol	Parameter	Conditions	Min.	Typ.	Max.	Unit
C _{iss}	Input Capacitance	V _{GS} =0V, V _{DS} =1000V, f=1.0MHz	-	2080	-	pF
C _{oss}	Output Capacitance		-	86	-	pF
C _{rss}	Reverse Transfer Capacitance		-	15	-	pF
Q _g	Total Gate Charge	I _D =30A, V _{DD} =800V V _{GS} =-4V/15V (Note 3)	-	120	-	nC
Q _{gs}	Gate to Source Charge		-	32.3	-	nC
Q _{gd}	Gate to Drain Charge		-	18.4	-	nC
t _{d(on)}	Turn-on Delay Time	I _D =33.3A, V _{DD} =800V, R _L =2.5Ω V _{GS} = -5/20V, (Note 3)	-	25	-	ns
t _r	Turn-on Rise Time		-	23	-	ns
t _{d(off)}	Turn-off Delay Time		-	50	-	ns
t _f	Turn-off Fall Time		-	18	-	ns

Body Diode Characteristics @ $T_C=25\text{ }^\circ\text{C}$ unless otherwise noted

Symbol	Parameter	Conditions	Min.	Typ.	Max.	Unit
V_{SD}	Drain-Source Diode Forward Voltage	$I_F=30\text{A}$	-	1.45	1.7	V
		$I_F=30\text{A}, T_C=175\text{ }^\circ\text{C}$	-	1.8	-	
t_{rr}	Reverse Recovery Time	$V_R=800\text{V}, I_{SD}=30\text{A}$ $di/dt=2250\text{A/us}$	-	27	-	ns
Q_{rr}	Reverse Recovery Charge		-	478	-	nC
I_{rrm}	Peak Reverse Reverse Current		-	25	-	A

Thermal Characteristics

Symbol	Parameter	Ratings	Unit
$R_{th(J-C), MOSFET}$	Thermal Resistance, Junction to case, MOSFET	0.3	$^\circ\text{C/W}$
$R_{th(J-C), Diode}$	Thermal Resistance, Junction to case, Diode	0.4	$^\circ\text{C/W}$
$R_{th(C-S)}$	Thermal Resistance, Case to Sink	0.05	$^\circ\text{C/W}$

Note:

1. Repetitive rating: pulse-width limited by maximum junction temperature
2. $V_{DD}=100\text{V}, L=5\text{mH}, V_{clamp}=1200\text{V}, V_G=15\text{V}, I_D=25.0\text{A}$
3. Essentially independent of operating temperature typical characteristics

Typical Performance Characteristics

Fig. 1. Typical Output Characteristics @ 25°C

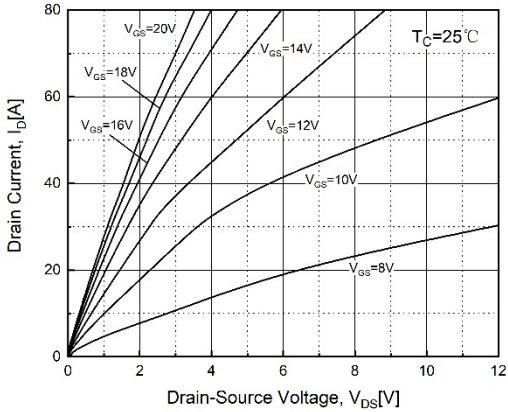

Fig. 2. Typical Output Characteristics @ 175°C

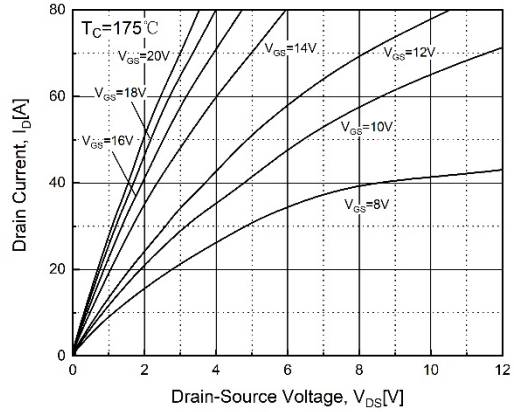

Fig. 3. Normalized On-Resistance vs. Junction Temperature

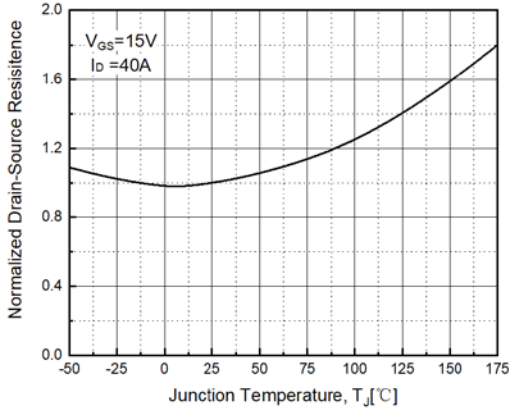

Fig. 4. On-Resistance vs. Drain Current for Various Temperatures

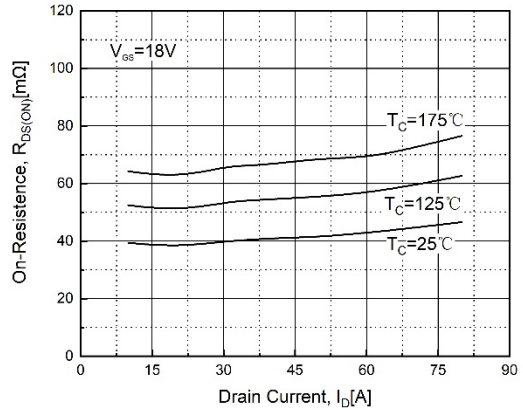

Fig. 5. On-Resistance vs. Drain Current for Various Gate Voltage

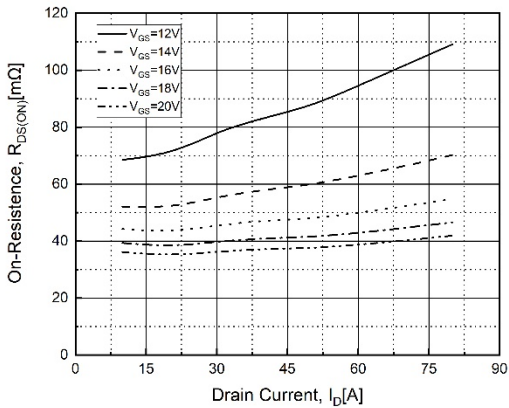
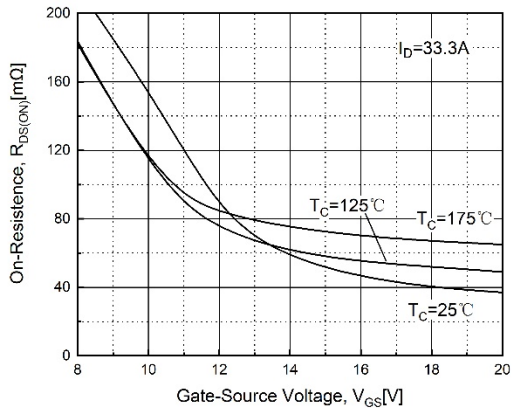

Fig. 6. On-Resistance vs. Gate Voltage for Various Temperatures



Typical Performance Characteristics

Fig. 7. Transfer Characteristics

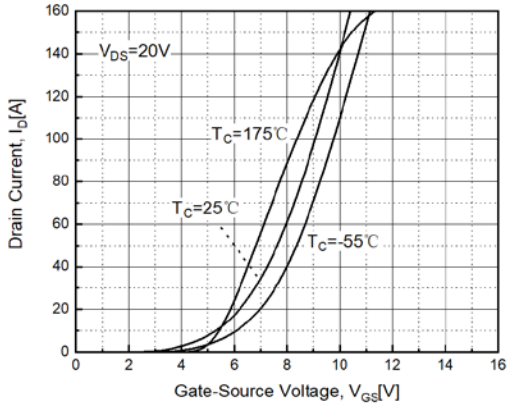

Fig. 8. Diode Forward Characteristics

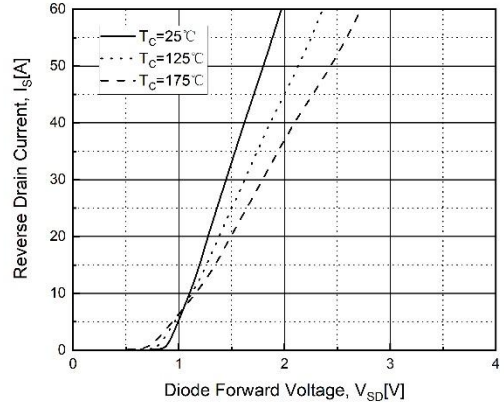

Fig. 9. Gate Charge Characteristics

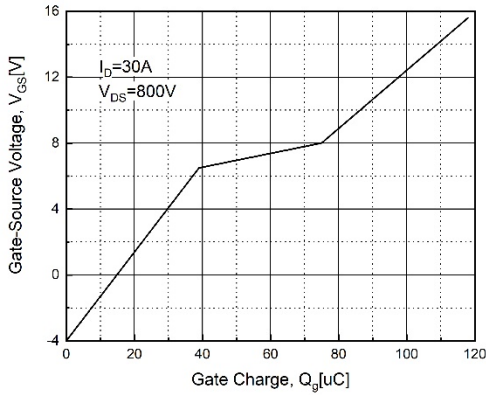

Fig. 10. Capacitance vs. Drain-to-Source Voltage

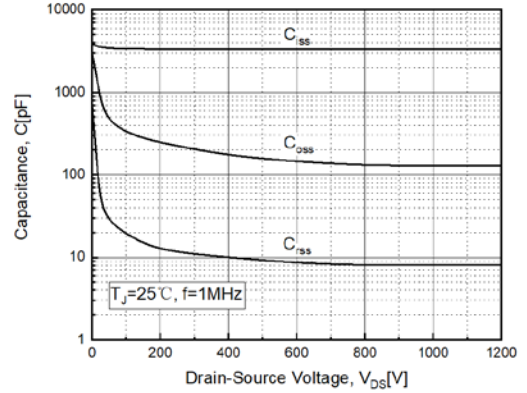
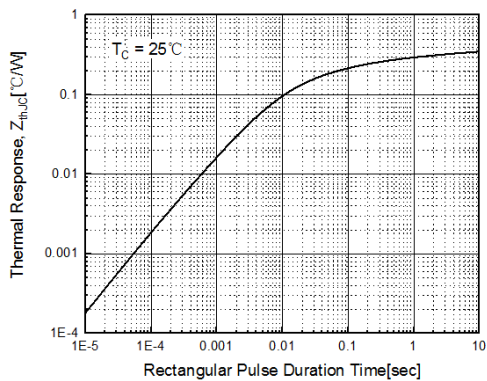
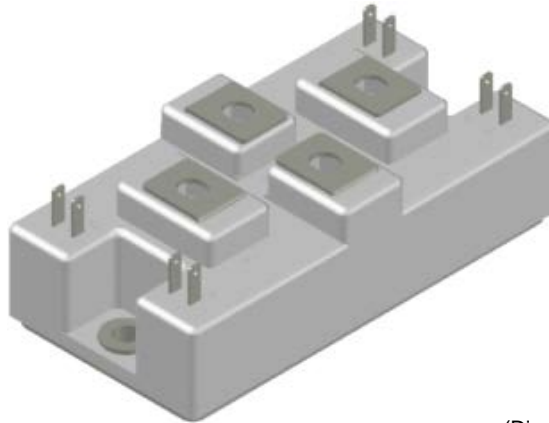

Fig. 11. Transient Thermal Impedance



Package Dimensions

D4



(Dimensions in Millimeters)

