

## TN1615 Serial 16A SCRs

### GENERAL DESCRIPTION :

High current density due to sing mesa technology. TN1615 series of silicon controlled rectifiers are specifically designed for medium power switching and phase control applications. TN1615 series are suitable for general purpose applications where a high gate sensitivity is required.

### Main Features:

$I_{T(RMS)}$	VDRM/VRRM	V <sub>TM</sub>
16 A	600V and 800 V	≤1.75 V

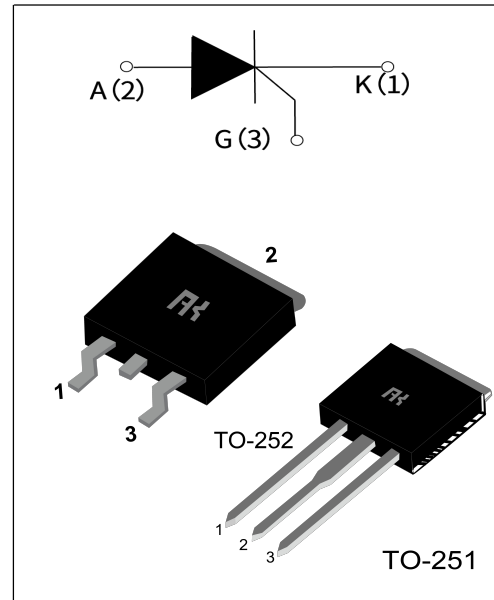

### Absolute Ratings(limiting values) :

Symbol	Parameter		value	Unit
$I_{T(RMS)}$	on-state RMS current(180°C conduction angle)		16	A
$I_{TSM}$	Non repetitive surge peak on-state current (T <sub>j</sub> = 25 °C)	tp= 8.3 ms	200	A
		tp = 10 ms	190	
$V_{DRM}$	Repetitive peak off-state voltage(T <sub>j</sub> =25°C)		600 and 800	V
$V_{RRM}$	Repetitive peak reverse voltage(T <sub>j</sub> =25°C)		600 and 800	V
$T_{stg}$ $T_j$	Storage and operating junction temperature range		- 40 to + 150 - 40 to + 125	°C
$I^2t$	I <sup>2</sup> t value for fusing T <sub>j</sub> = 125°C	tp = 10 ms	180	A <sup>2</sup> s
$dI/dt$	Critical rate of rise of on-state current I <sub>G</sub> =2xI <sub>GT</sub> , tr≤100ns		50	A/μs
$I_{GM}$	Peak gate current tp=20us T <sub>j</sub> =125°C		4	A
$P_{GM}$	Peak gate power tp=20us T <sub>j</sub> =125°C		5	W
$P_{G(av)}$	Average gate power dissipation T <sub>j</sub> =125°C		1	W

**Electrical Characteristics :**

Symbol	Test Condition	range	Value	Unit	
<b>I<sub>GT</sub></b>	V <sub>D</sub> =12V    R <sub>L</sub> =3.3kΩ	T <sub>j</sub> =25°C	MAX	15	mA
<b>V<sub>GT</sub></b>		T <sub>j</sub> =25°C	MAX	1.5	V
<b>V<sub>GD</sub></b>	V <sub>D</sub> =V <sub>DRM</sub> R <sub>L</sub> =3.3kΩ	T <sub>j</sub> =125°C	MIN	0.2	V
<b>t<sub>gt</sub></b>	V <sub>D</sub> =V <sub>DRM</sub> I <sub>G</sub> = 500mA    dI <sub>G</sub> /dt = 0.2A/μs	T <sub>j</sub> =25°C	TYP	2	μs
<b>I<sub>L</sub></b>	V <sub>D</sub> =12V    I <sub>GT</sub> = 0.1 A	T <sub>j</sub> =25°C	TYP	40	mA
<b>I<sub>H</sub></b>	I <sub>T</sub> = 500mA gate open	T <sub>j</sub> =25°C	MAX	30	mA
<b>V<sub>TM</sub></b>	I <sub>TM</sub> = 2*I <sub>T (RMS)</sub> tp=380μs	T <sub>j</sub> =25°C	MAX	1.75	V
<b>I<sub>DRM</sub></b>	V <sub>D</sub> =V <sub>DRM</sub> , V <sub>R</sub> =V <sub>RRM</sub>	T <sub>j</sub> =125°C	TYP	5	μA
<b>I<sub>RRM</sub></b>		T <sub>j</sub> =125°C	MAX	2	mA
<b>dV/dt</b>	V <sub>D</sub> =67%V <sub>DR</sub> exponential waveform; R <sub>GK</sub> = 100 Ω	T <sub>j</sub> =125°C	TYP	500	V/μs

**Thermal Resistances :**

Symbol	Parameter	Value	Unit	
<b>R<sub>th (j-mb)</sub></b>	junction to mounting case	TO-251/252	1.1	°C/W

**FIG.1** Maximum power dissipation versus RMS on-state current

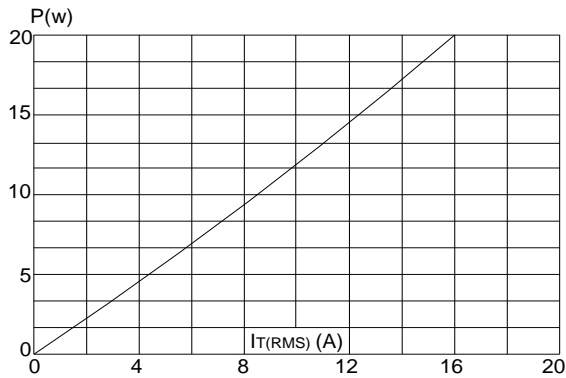

**FIG.2:** RMS on-state current versus case temperature

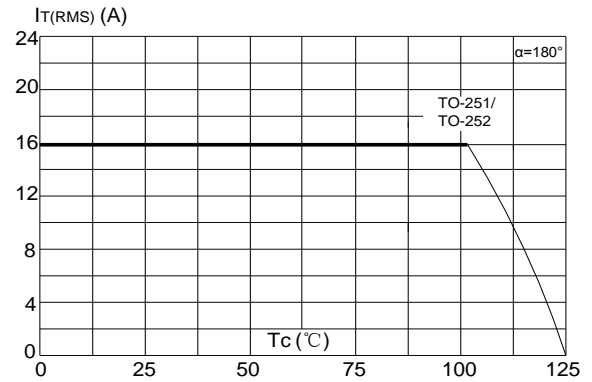

**FIG.3:** Surge peak on-state current versus number of cycles

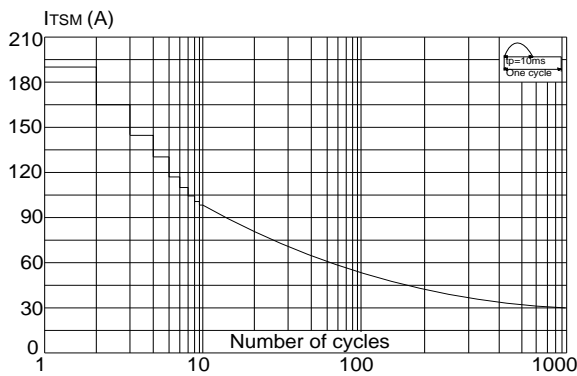

**FIG.4:** On-state characteristics (maximum values)

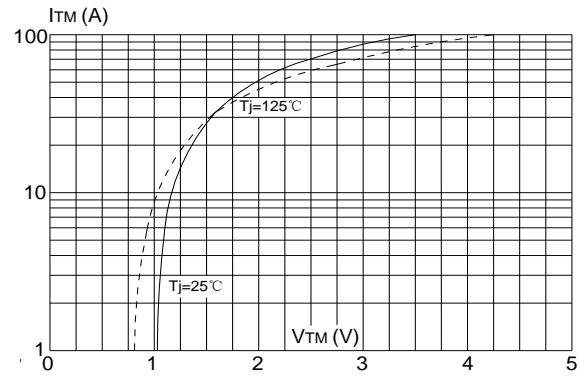

**FIG.5:** Non-repetitive surge peak on-state current for a sinusoidal pulse with width  $t_p < 10\text{ms}$ , and corresponding value of  $I^2t$  ( $di/dt < 50\text{A}/\mu\text{s}$ )

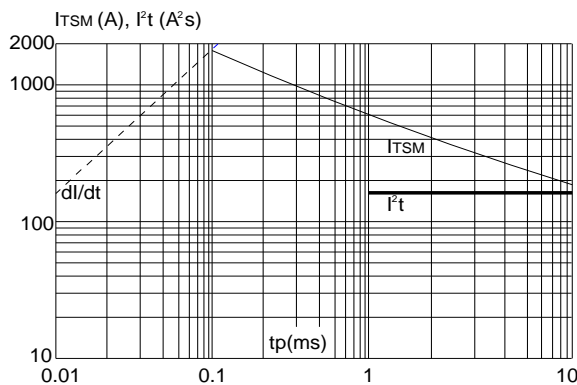

**FIG.6:** Relative variations of gate trigger current, holding current and latching current versus junction temperature

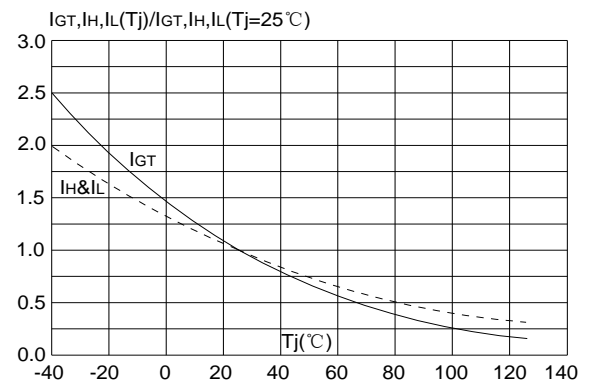

**Ordering Information**

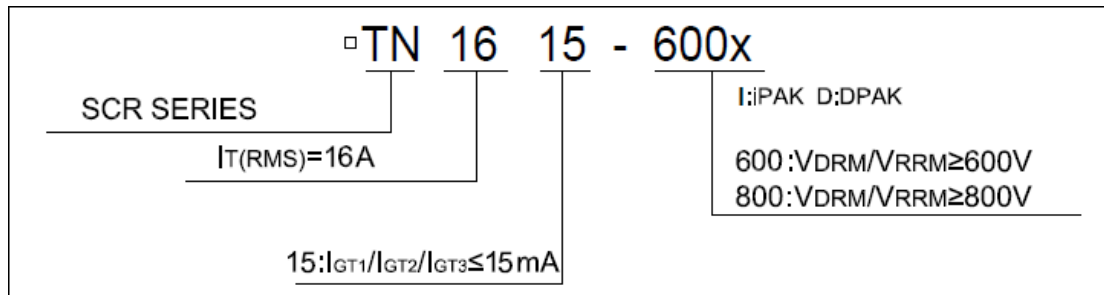

**Package Mechanical Data :**

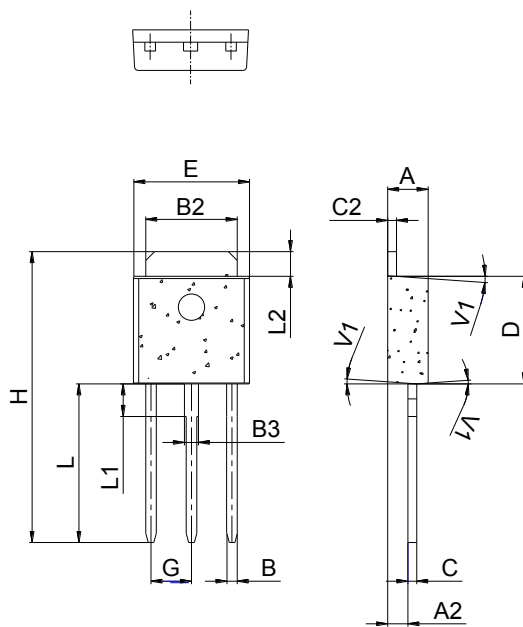

TO-251

Ref.	Dimensions					
	Millimeters			Inches		
	Min.	Typ.	Max.	Min.	Typ.	Max.
A	2.20		2.40	0.086		0.095
A2	0.90		1.20	0.035		0.047
B	0.55		0.65	0.022		0.026
B2	5.10		5.40	0.200		0.213
B3	0.76		0.85	0.030		0.033
C	0.45		0.62	0.018		0.024
C2	0.48		0.62	0.019		0.024
D	6.00		6.20	0.236		0.244
E	6.40		6.70	0.252		0.264
G		2.30			0.091	
H	16.0		17.0	0.630		0.669
L	8.90		9.40	0.350		0.370
L1	1.80		1.90	0.071		0.075
L2	1.37		1.50	0.054		0.059
V1		4°			4°	

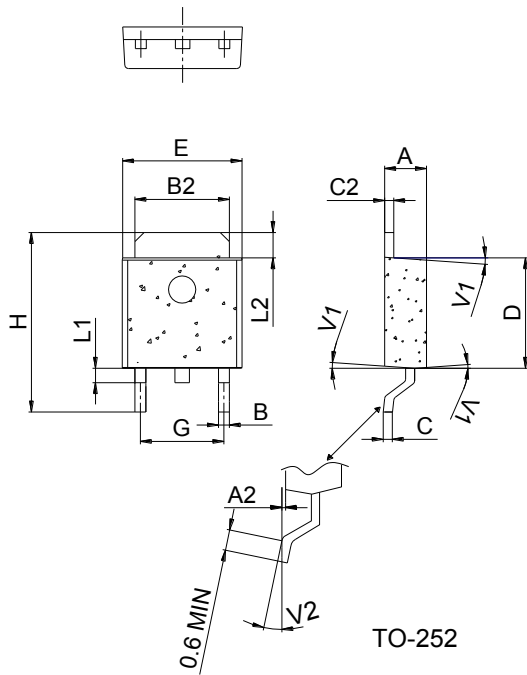

Ref.	Dimensions					
	Millimeters			Inches		
	Min.	Typ.	Max.	Min.	Typ.	Max.
A	2.20		2.40	0.086		0.095
A2	0.03		0.23	0.001		0.009
B	0.55		0.65	0.022		0.026
B2	5.10		5.40	0.200		0.213
C	0.45		0.62	0.018		0.024
C2	0.48		0.62	0.019		0.024
D	6.00		6.20	0.236		0.244
E	6.40		6.70	0.252		0.264
G	4.40		4.70	0.173		0.185
H	9.35		10.6	0.368		0.417
L1	1.30		1.70	0.051		0.067
L2	1.37		1.50	0.054		0.059
V1		4°			4°	
V2	0°		8°	0°		8°

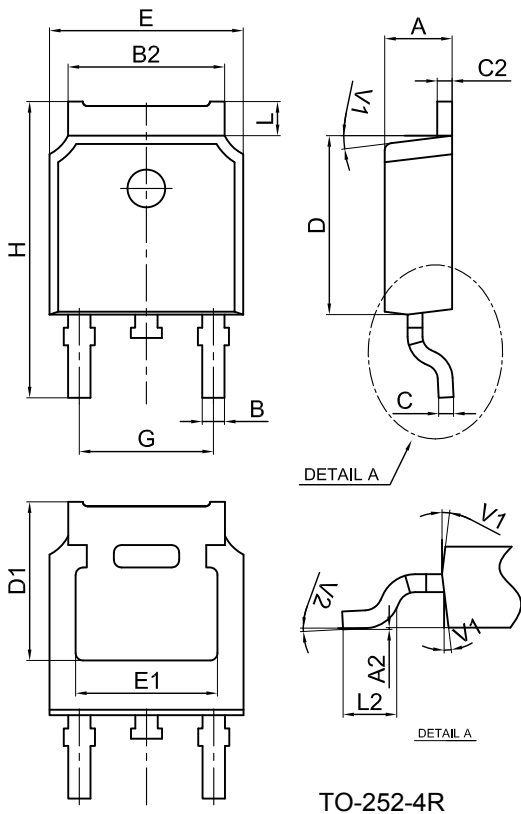

Ref.	Dimensions					
	Millimeters			Inches		
	Min.	Typ.	Max.	Min.	Typ.	Max.
A	2.10		2.50	0.083		0.098
A2	0		0.10	0		0.004
B	0.66		0.86	0.026		0.034
B2	5.18		5.48	0.202		0.216
C	0.40		0.60	0.016		0.024
C2	0.44		0.58	0.017		0.023
D	5.90		6.30	0.232		0.248
D1	5.30REF			0.209REF		
E	6.40		6.80	0.252		0.268
E1	4.63			0.182		
G	4.47		4.67	0.176		0.184
H	9.50		10.70	0.374		0.421
L	1.09		1.21	0.043		0.048
L2	1.35		1.65	0.053		0.065
V1		7°			7°	
V2	0°		6°	0°		6°

*Note: This package drawing may slightly differ from the physical package. However, all the specified dimensions are guaranteed.*