

TN615 Seria 16A SCRs

GENERAL DESCRIPTION :

The TN615 family of Silicon Controlled Rectifiers are high performance Glasspassivated, sensitive gate thyristors in a plastic envelope, intended for use in general purpose switching and phase control applications. These devices are intended to be interfaced directly to microcontrollers, logic integrated circuits and other low power gate trigger circuits.

Main Features:

$I_{T(RMS)}$	V_{DRM}/V_{RRM}	V_{TM}
6 A	600V and 800 V	≤ 1.6 V

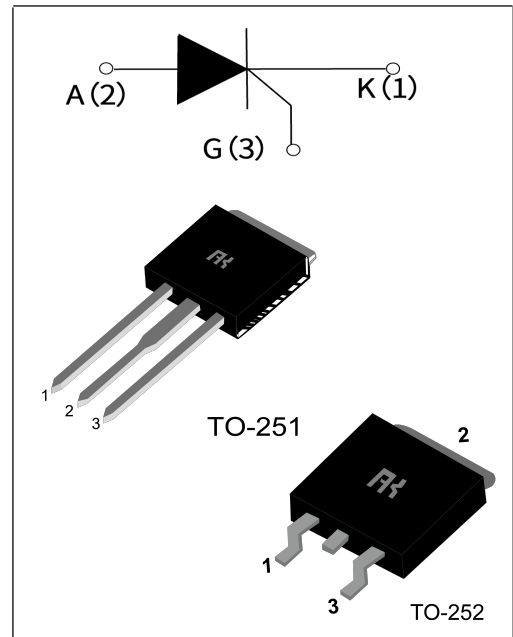

Absolute Ratings(limiting values) :

Symbol	Parameter		value	Unit
$I_{T(RMS)}$	on-state RMS current(180°C conduction angle)		6	A
I_{TSM}	Non repetitive surge peak on-state current ($T_j = 25^\circ\text{C}$)	$t_p = 8.3$ ms	73	A
		$t_p = 10$ ms	70	
V_{DRM}	Repetitive peak off-state voltage($T_j = 25^\circ\text{C}$)		600 and 800	V
V_{RRM}	Repetitive peak reverse voltage($T_j = 25^\circ\text{C}$)		600 and 800	V
T_{stg} T_j	Storage and operating junction temperature range		- 40 to + 150 - 40 to + 125	$^\circ\text{C}$
I^2t	I^2t value for fusing $T_j = 125^\circ\text{C}$	$t_p = 10$ ms	25	A^2s
dI/dt	Critical rate of rise of on-state current $I_G = 2 \times I_{GT}$, $t_r \leq 100\text{ns}$		50	$\text{A}/\mu\text{s}$

Electrical Characteristics :

Symbol	Test Condition	range	Value	Unit	
I_{GT}	V _D =12V R _L =3.3kΩ	T _j =25°C	MAX	15	mA
V_{GT}		T _j =25°C	MAX	1.5	V
V_{GD}	V _D =V _{DRM} R _L =3.3kΩ	T _j =125°C	MIN	0.2	V
t_{gt}	V _D =V _{DRM} I _G = 500mA dI _G /dt = 0.2A/μs	T _j =25°C	TYP	2	μs
I_L	V _D =12V I _{GT} = 0.1 A	T _j =25°C	TYP	50	mA
I_H	I _T = 500mA gate open	T _j =25°C	MAX	30	mA
V_{TM}	I _{TM} = 2*I _{T (RMS)} tp=380μs	T _j =25°C	MAX	1.6	V
I_{DRM} I_{RRM}	V _D =V _{DRM} , V _R =V _{RRM}	T _j =125°C	TYP	10	μA
		T _j =125°C	MAX	2	mA
dV_D/dt	V _D =67%V _{DR} exponential waveform; R _{GK} = 100 Ω	T _j =125°C	TYP	200	V/μs

Thermal Resistances :

Symbol	Parameter	Value	Unit	
R_{th (j-c)}	junction to mounting base	TO-251/252	2.5	°C/W
R_{th (j-a)}	Junction to ambient	TO-251/252	60	°C/W

Fig.1: Maximum average power dissipation versus average on-state current .

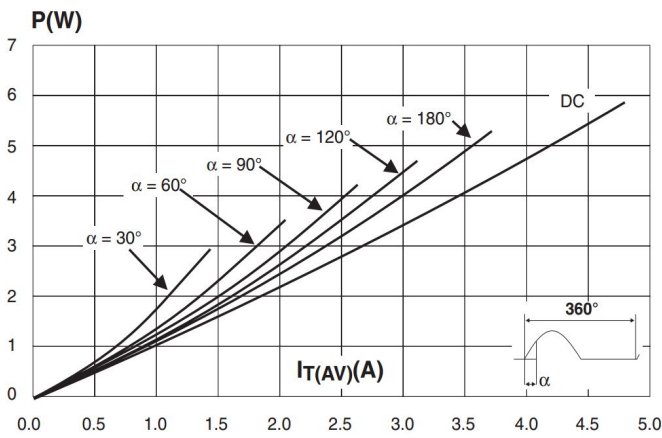

Fig.2 : Correlation between maximum average power dissipation and maximum allowable temperatures (Tamb and Tlead) for different thermal resistances heat sink+contact.

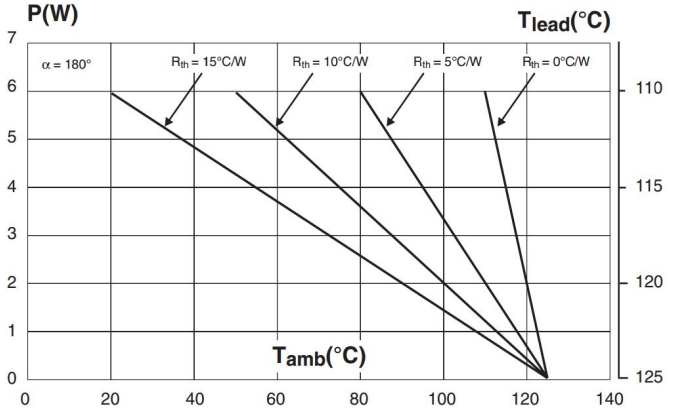

Fig.3 : Average and D.C. on-state current versus case temperature.

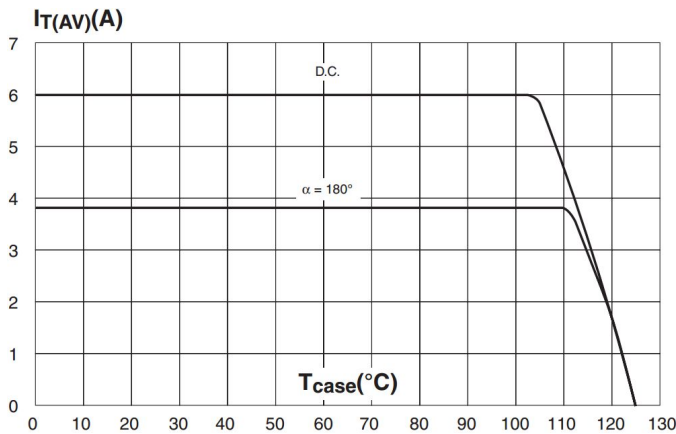

Fig.4 : Average and D.C. on-state current versus case temperature.

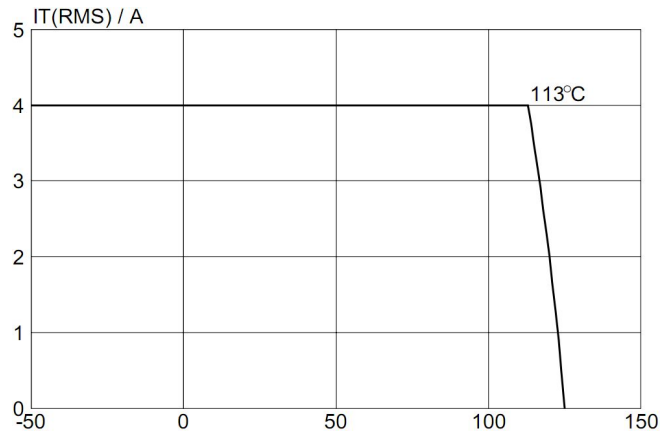

Fig.5 : Relative variation of thermal impedance versus pulse duration.

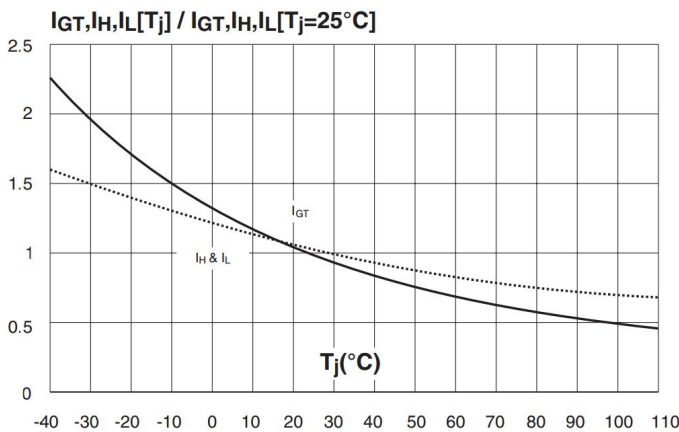

Fig.6 : Relative variation of thermal impedance versus pulse duration.

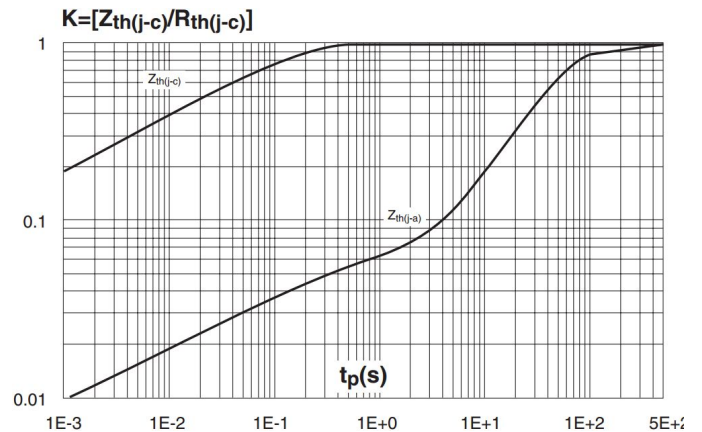

Fig.7 : Relative variation of gate trigger current and holding current versus junction temperature.

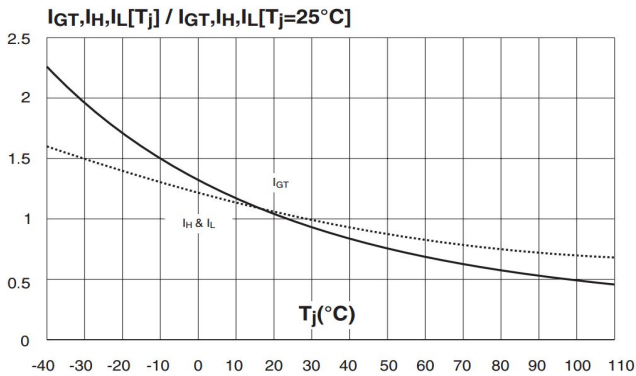
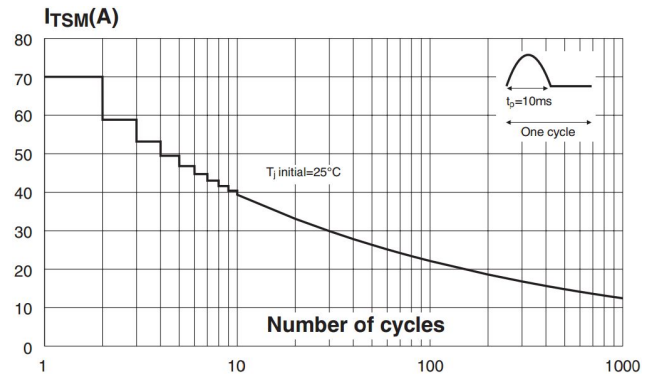
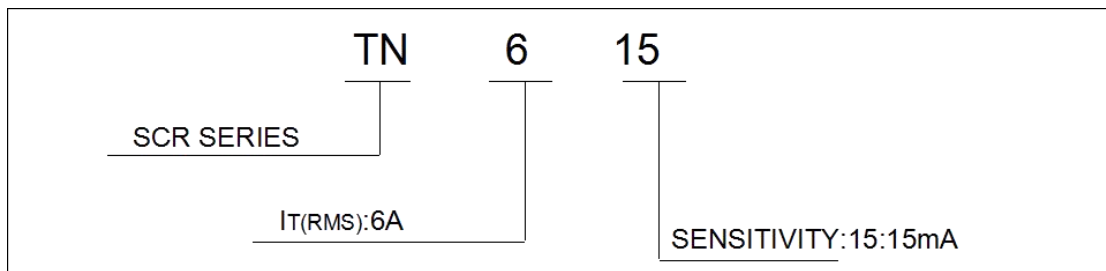

Fig.6: Non repetitive surge peak on-state current versus number of cycles.



Ordering Information



Package Mechanical Data :

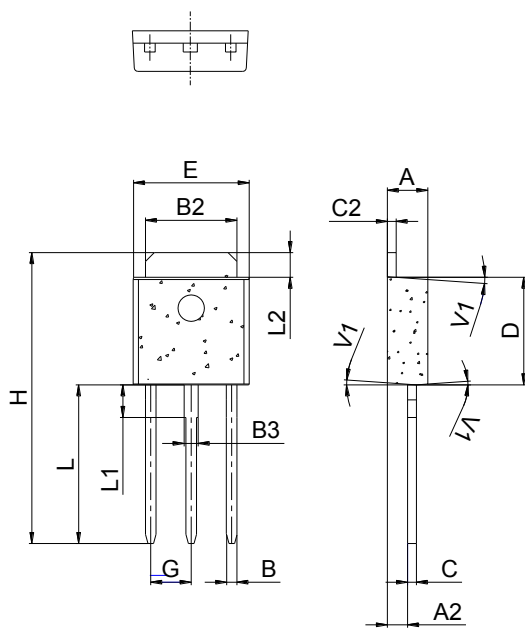

TO-251

Ref.	Dimensions					
	Millimeters			Inches		
	Min.	Typ.	Max.	Min.	Typ.	Max.
A	2.20		2.40	0.086		0.095
A2	0.90		1.20	0.035		0.047
B	0.55		0.65	0.022		0.026
B2	5.10		5.40	0.200		0.213
B3	0.76		0.85	0.030		0.033
C	0.45		0.62	0.018		0.024
C2	0.48		0.62	0.019		0.024
D	6.00		6.20	0.236		0.244
E	6.40		6.70	0.252		0.264
G		2.30			0.091	
H	16.0		17.0	0.630		0.669
L	8.90		9.40	0.350		0.370
L1	1.80		1.90	0.071		0.075
L2	1.37		1.50	0.054		0.059
V1		4°			4°	

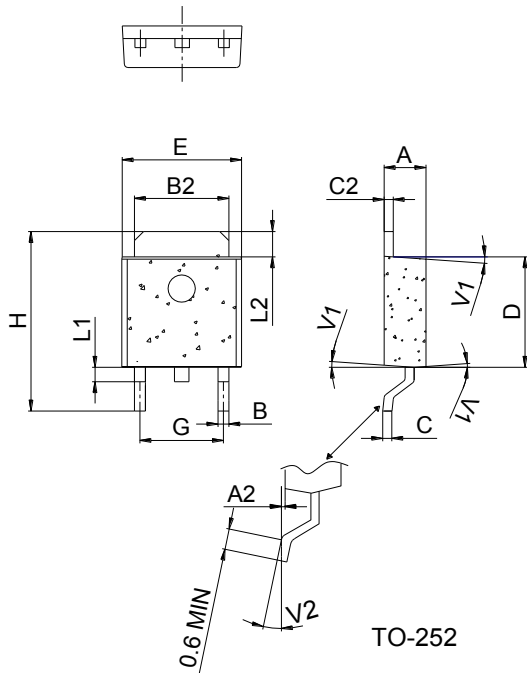

Ref.	Dimensions					
	Millimeters			Inches		
	Min.	Typ.	Max.	Min.	Typ.	Max.
A	2.20		2.40	0.086		0.095
A2	0.03		0.23	0.001		0.009
B	0.55		0.65	0.022		0.026
B2	5.10		5.40	0.200		0.213
C	0.45		0.62	0.018		0.024
C2	0.48		0.62	0.019		0.024
D	6.00		6.20	0.236		0.244
E	6.40		6.70	0.252		0.264
G	4.40		4.70	0.173		0.185
H	9.35		10.6	0.368		0.417
L1	1.30		1.70	0.051		0.067
L2	1.37		1.50	0.054		0.059
V1		4°			4°	
V2	0°		8°	0°		8°

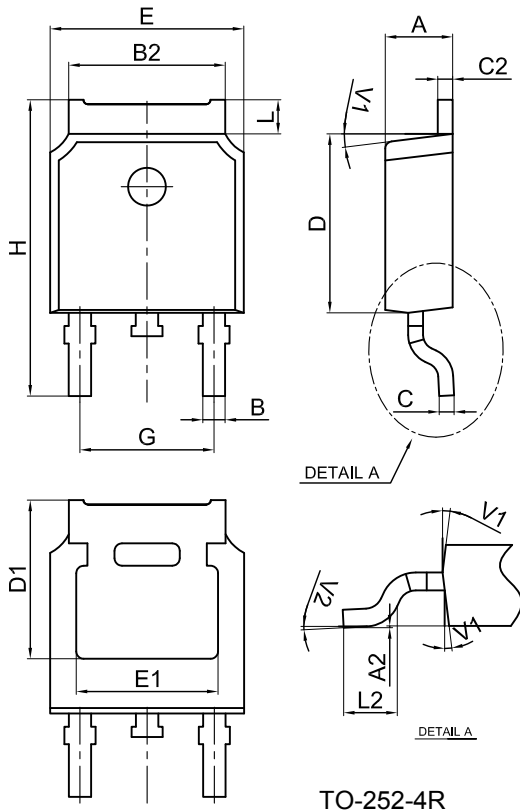

Ref.	Dimensions					
	Millimeters			Inches		
	Min.	Typ.	Max.	Min.	Typ.	Max.
A	2.10		2.50	0.083		0.098
A2	0		0.10	0		0.004
B	0.66		0.86	0.026		0.034
B2	5.18		5.48	0.202		0.216
C	0.40		0.60	0.016		0.024
C2	0.44		0.58	0.017		0.023
D	5.90		6.30	0.232		0.248
D1	5.30REF			0.209REF		
E	6.40		6.80	0.252		0.268
E1	4.63			0.182		
G	4.47		4.67	0.176		0.184
H	9.50		10.70	0.374		0.421
L	1.09		1.21	0.043		0.048
L2	1.35		1.65	0.053		0.065
V1		7°			7°	
V2	0°		6°	0°		6°