

BT131 Serial Standard TRIACS

GENERAL DESCRIPTION :

BT131 series triacs with low holding and latching current are especially recommended for use on middle and small resistance type power load.

Main Features:

$I_{T(RMS)}$	V_{DRM}/V_{RRM}	V_{TM}
1 A	600V and 800 V	$\leq 1.7V$

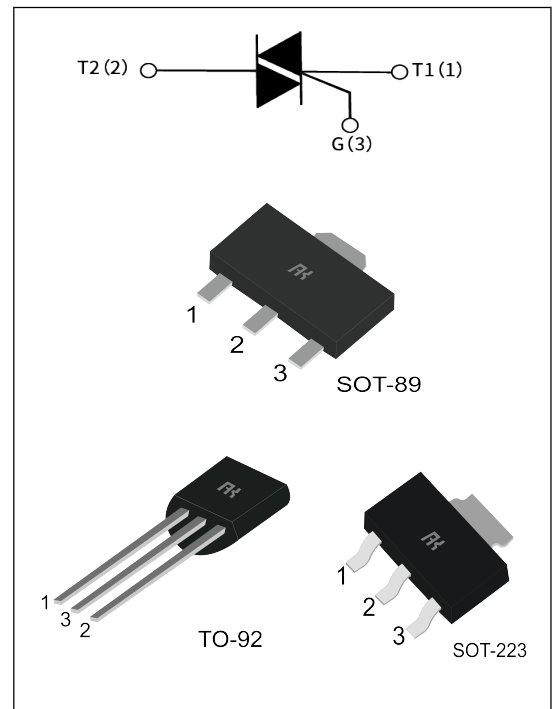

Absolute Ratings(limiting values) :

Symbol	Parameter	Value	Unit	
T_{stg}	Storage junction temperature range	- 40 to + 150	$^{\circ}C$	
T_j	Operating junction temperature range	- 40 to + 125	$^{\circ}C$	
$I_{T(RMS)}$	RMS on-state current	TO-92 (TC=51 $^{\circ}C$)	1	A
		SOT-223/SOT-89 (TC=70 $^{\circ}C$)		
I_{TSM}	Non repetitive surge peak on-state current (full cycle, F=50Hz)	16	A	
V_{DRM}	Repetitive peak off-state voltage ($T_j = 25^{\circ}C$)	600 and 800	V	
V_{RRM}	Repetitive peak reverse voltage ($T_j = 25^{\circ}C$)	600 and 800	V	
V_{DSM}	Non repetitive surge peak Off-state voltage	$V_{DRM} + 100$	V	
V_{RSM}	Non repetitive peak reverse voltage	$V_{RRM} + 100$	V	
I^2t	I^2t value for fusing $t_p = 10$ ms	1.28	A^2s	
d_i/d_t	Critical rate of rise of on-state current ($I_G = 2 \times I_{GT}$)	10	$A/\mu s$	
I_{GM}	Peak gate current	2	A	

P_{G(AV)}	Average gate power dissipation	0.5	W
P_{GM}	Peak gate power	5	W

Electrical Characteristics (T_j=25°C unless otherwise specified) :

● **SNUBBERLESS(3 Quadrants)**

Symbol	Test Condition	Quadrant	Range	Value	Unit
				EW	
I_{GT}	V _D =12V R _L =33Ω	I-II-III	MAX	5	mA
V_{GT}		I-II-III	MAX	1.5	
V_{GD}	V _D =V _{DRM} T _j =125°C R _L =3.3kΩ	I-II-III	MIN	0.2	V
I_L	I _G =1.2 I _{GT}	I-III	TYP	5	mA
		II-IV		10	
I_H	IT= 100mA		MAX	7	mA
dV/dt	V _D =2/3V _{DRM} Gate Open T _j =125°C		MIN	20	V/μs

● **STANDARD(4 Quadrants)**

Symbol	Test Condition	Quadrant	Range	Value	Unit
				E	
I_{GT}	V _D =12V R _L =33Ω	I-II-III	MAX	5	mA
		IV	MAX	10	
V_{GT}		I-II-III-IV	MAX	1.5	V

V_{GD}	V _D =V _{DRM} T _j =125°C R _L =3.3kΩ	I-II-III-IV	MIN	0.2	V
I_L	I _G =1.2 I _{GT}	I-III	TYP	5	mA
		II-IV		10	
I_H	I _T = 200mA		MAX	7	mA
dV/dt	V _D =2/3V _{DRM} Gate Open T _j =125°C		MIN	20	V/μs

STATIC CHARACTERISTICS

Symbol	Parameter			Value(MAX)	Unit
V_{TM}	I _{TM} =1.4A tp= 380μs	T _j =25°C	MAX	1.7	V
I_{DRM} I_{RRM}	V _D =V _{DRM} , V _R =V _{RRM}	T _j =25°C	MAX	10	μ A
		T _j =125°C		500	

Thermal Resistances :

Symbol	Parameter		Value	Unit
R _{th(j-c)}	junction to case(AC)	TO-92	60	°C/W
		SOT-89/SOT-223	23	

Ordering Information:

BT 131 - 600 E TRIAC SERIES I _{T(RMS)} :1A	E: IGT ₁₋₃ ≤10mA STANDARD EW:IGT ₁₋₃ ≤10mA SNUBBERLESS 600:V _{DRM} /V _{RRM} ≥600 800:V _{DRM} /V _{RRM} ≥800
--	---

Fig.1: Maximum power dissipation versus RMS on-state current

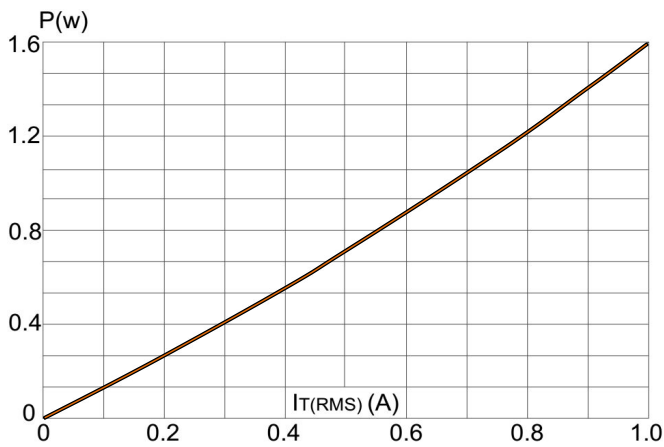

Fig.2 : RMS on-state current versus case temperature

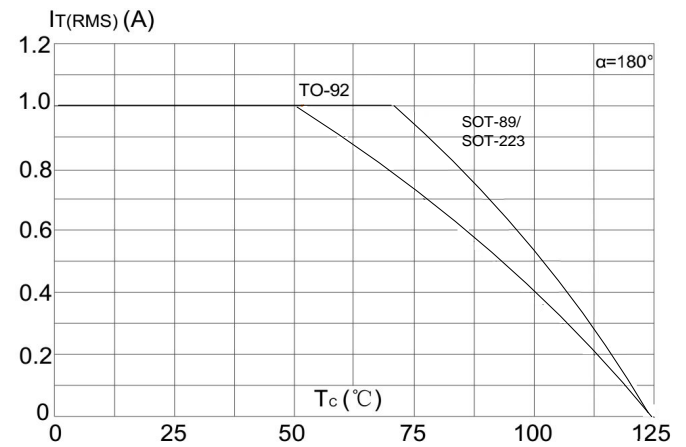

Fig.3 : Surge peak on-state current versus number of cycles

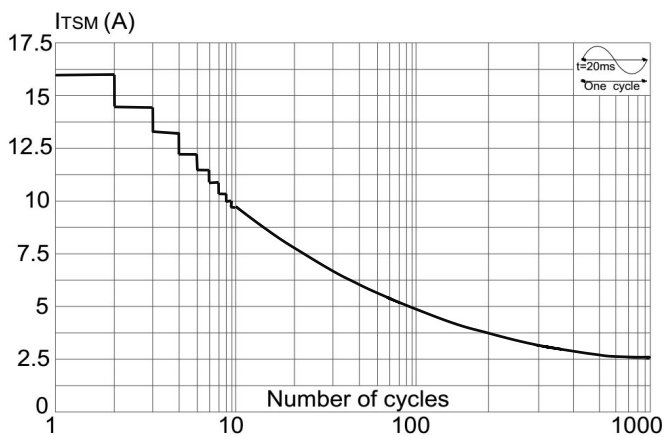

Fig.4 : On-state characteristics (maximum values)

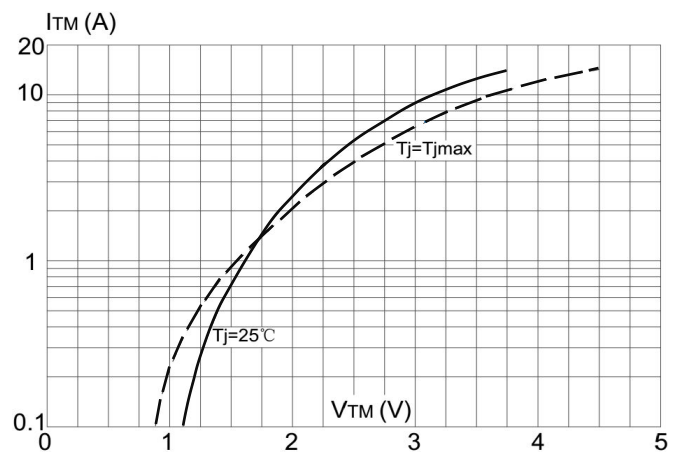

Fig.5: Non-repetitive surge peak on-state current for a sinusoidal pulse with width $t_p < 20\text{ms}$ and corresponding value of $I^2 t$ ($dI/dt < 10\text{A}/\mu\text{s}$)

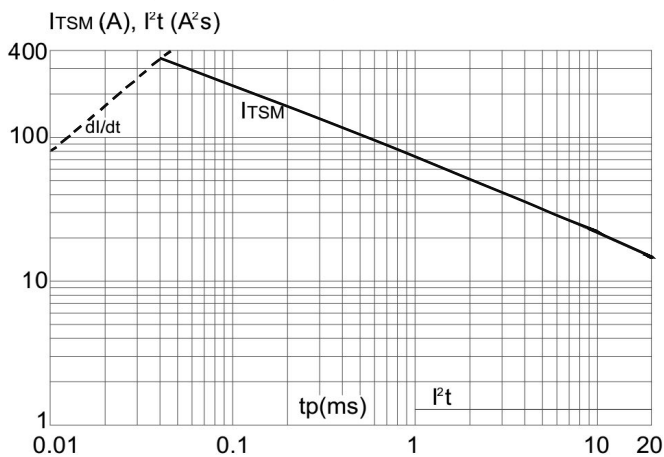
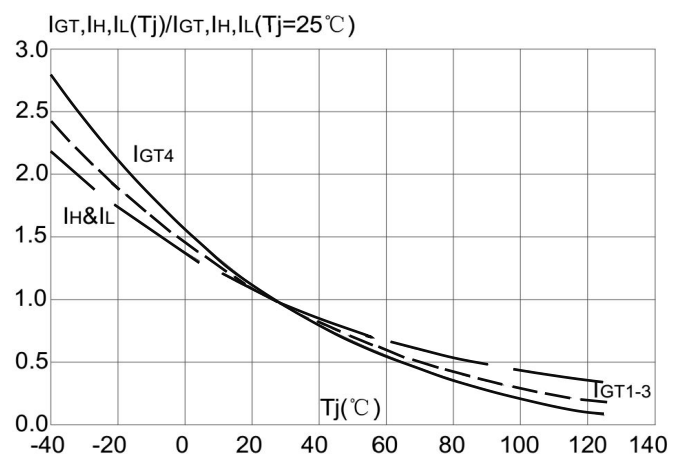

Fig.6: Relative variations of gate trigger current versus junction temperature



Package Mechanical Data :

Unit:mm

TO-92

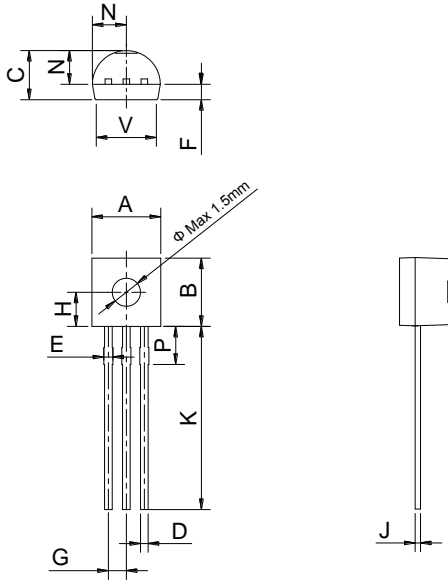

Ref.	Dimensions					
	Millimeters			Inches		
	Min.	Typ.	Max.	Min.	Typ.	Max.
A	4.45		5.20	0.175		0.205
B	4.32		5.33	0.170		0.210
C	3.18		4.19	0.125		0.165
D	0.407		0.533	0.016		0.021
E	0.60		0.80	0.024		0.031
F	-	1.1	-	-	0.043	-
G	-	1.27	-	-	0.050	-
H	-	2.30	-	-	0.091	-
J	0.36		0.50	0.014		0.020
K	12.70		15.0	0.500		0.591
N	2.04		2.66	0.080		0.105
P	1.86		2.06	0.073		0.081
V	-		4.3	-		0.169

SOT-223

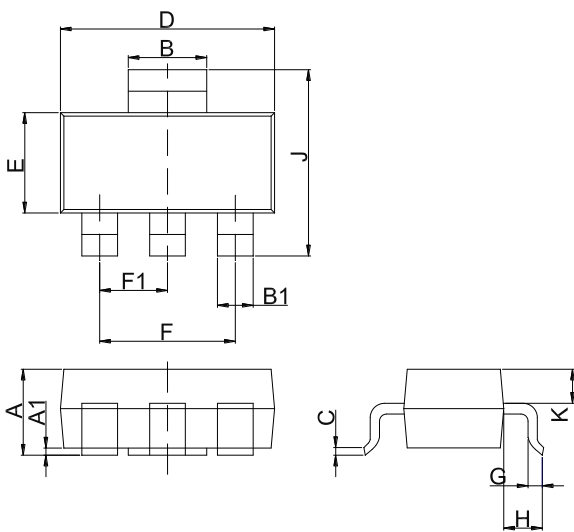

Ref.	Dimensions					
	Millimeters			Inches		
	Min.	Typ.	Max.	Min.	Typ.	Max.
A	1.5	1.6	1.8	0.059	0.063	0.071
A1	0	0.06	0.10	0	0.002	0.004
B	2.9	3.0	3.1	0.114	0.118	0.122
B1	0.6	0.7	0.8	0.024	0.028	0.031
C	0.22	0.26	0.32	0.009	0.010	0.013
D	6.3	6.5	6.7	0.248	0.256	0.264
E	3.3	3.5	3.7	0.130	0.138	0.146
F		4.6			0.181	
F1		2.3			0.091	
G	0.7	0.9	1.1	0.028	0.035	0.043
H	1.5	1.75	2.0	0.059	0.069	0.079
J	6.7	7.0	7.3	0.264	0.276	0.287
K	0.8	0.9	1.0	0.031	0.035	0.039

SOT-89

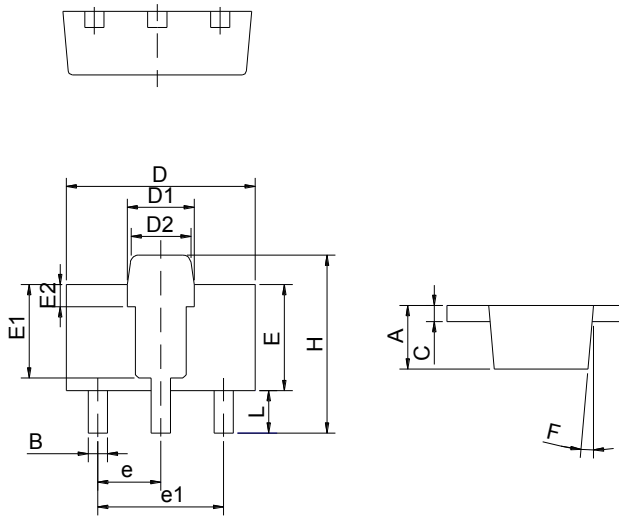

Ref.	Dimensions					
	Millimeters			Inches		
	Min.	Typ.	Max.	Min.	Typ.	Max.
A	1.40		1.60	0.055		0.063
B	0.40		0.52	0.016		0.020
C	0.35		0.41	0.014		0.016
D	4.40		4.60	0.173		0.181
D1	1.50		1.70	0.059		0.067
D2	1.30		1.50	0.051		0.059
E	2.40		2.60	0.094		0.102
E1		2.20			0.087	
E2		0.52			0.020	
e		1.50			0.059	
e1		3.00			0.118	
F		5°			0.197°	
H	4.05		4.25	0.159		0.167
L	0.89		1.20	0.035		0.047